

Sept. 2, 1958

W. HUB

2,850,104

BLADE WHEEL PROPELLER WITH REMOVABLE BLADES

Filed July 28, 1955

2 Sheets-Sheet 1

Fig. 1

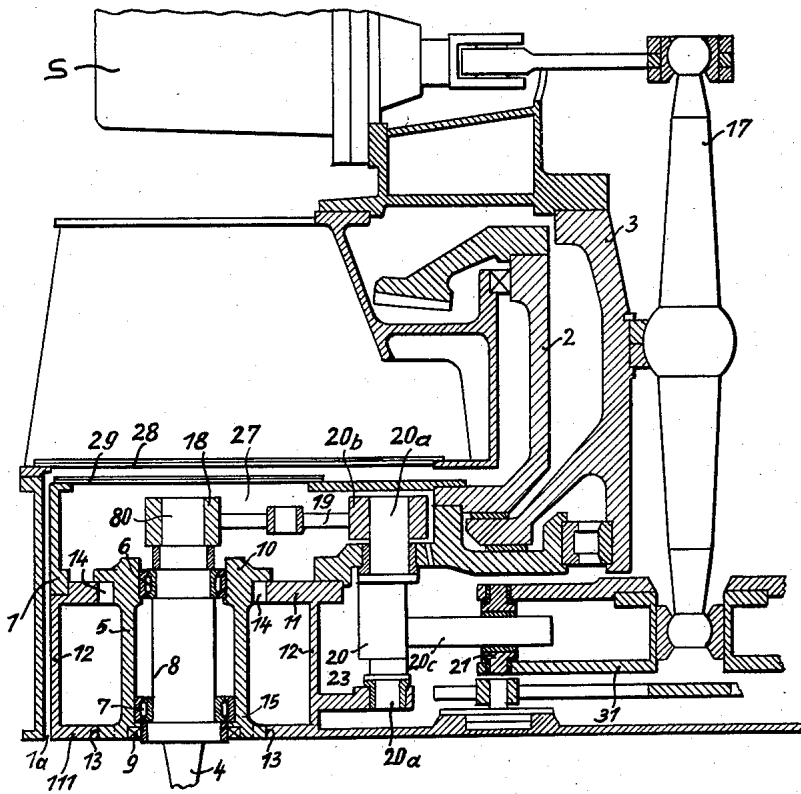
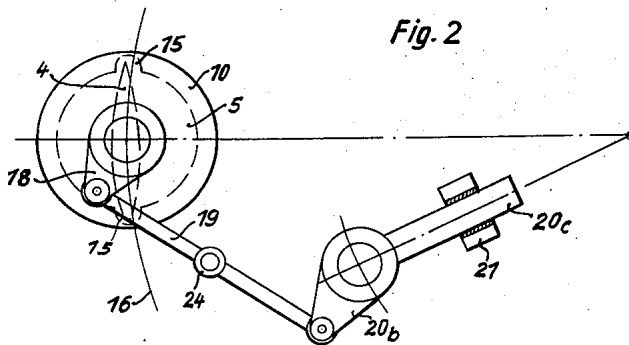

Fig. 2



INVENTOR.

Wilhelm Hub

BY

Walter Becking
Patent Agent

1

2,850,104

BLADE WHEEL PROPELLER WITH REMOVABLE BLADES

Wilhelm Hub, Heidenheim (Brenz), Germany, assignor to J. M. Voith G. m. b. H., Maschinenfabrik, Heidenheim (Brenz), Germany

Application July 28, 1955, Serial No. 524,853

4 Claims. (Cl. 170-147)

The present invention relates to ship propellers and, more particularly, to blade wheel propellers with removable blades.

In the course of the normal wear, parts of propellers of the above mentioned type such as the bearings for the blades, and seals for the shanks have to be replaced or repaired. Sometimes, for instance when the ship suffers damages due to running aground or hitting heavy floating bodies, it is even necessary to replace one or more complete blades. In connection with such replacements or repairs it is known to remove the blades having their shanks arranged in a cone-shaped sleeve and to withdraw the blades downwardly by connecting or screwing an ear to the blade pivots from the interior of the ship, connecting a cable to said ear and then to lower the blade into the water. Thereupon the cable is pulled from the side of the ship for instance from a second boat and the blade is then pulled out of the water from said second boat. Such operations are rather cumbersome and can be carried out only in calm waters. Furthermore, it has been found necessary in practice to grind each blade shank into the respective sleeve pertaining thereto in order to secure a proper fitting of the shank. This necessity makes it rather difficult to install replacement blades because the said sleeve is not easily accessible for such operations. In addition thereto, a proper fitting of the replacement blades to be installed is frequently endangered due to the fact that the water is dirty and the blade to be installed has to be moved through such water.

In view of the above outlined difficulties, the idea was advanced in case of replacements or repairs to withdraw the blades upwardly, i. e. into the interior of the ship; However, all attempts heretofore made to this effect have failed.

It is, therefore, an object of the present invention to provide a blade wheel construction which will overcome the above mentioned drawbacks.

It is another object of this invention to provide a blade wheel construction which will make it possible without any difficulties for purposes of repair or replacement, to withdraw the blades of such blade wheel propeller upwardly into the interior of the ship.

It is still another object of this invention to provide a blade wheel construction as set forth in the two preceding paragraphs, which will be reliable and relatively simple.

These and other objects and advantages of the invention will appear more clearly from the following specification in connection with the accompanying drawings, in which:

Fig. 1 is a diagrammatic section through a portion of a blade wheel propeller according to the invention, parts of Fig. 1 being shown offset by 90° for purposes of clarity.

Fig. 2 illustrates on the same scale as that of Fig. 1 a top view of a portion of a blade wheel construction

2

according to the invention and a portion of the driving lever system therefor.

Fig. 3 is a diagrammatic cross section through a portion of a modified blade wheel construction according to the invention.

Fig. 4 illustrates a top view of a portion of the driving system for the blade wheel construction of Fig. 3.

General arrangement

According to the present invention, the blades together with the bearing means therefor are respectively arranged in sleeves which in their turn are inserted in a corresponding opening of the wheel body in which opening they are detachably connected to the wheel body. Furthermore, the blade shanks with the blade pivots extend upwardly beyond the sleeves and they are likewise detachably connected to the blade actuating lever system which in its turn is operatively connected to the control center of the blade wheel construction. In particular, the blade driving lever system also comprises a two-arm lever which preferably simultaneously serves as member for varying the blade oscillation. This two-arm lever comprises a rotatable pivot journaled in the wheel body and extending parallel or nearly parallel to the blade shanks or blade pivots, while both lever arms of said two-arm lever are arranged in different planes. One of said lever arms is located at the level of the members connecting said one lever arm with the control center, whereas the other lever arm is located above the bearings for the blades where said other lever arm is connected with the blade pivots extending beyond the bearings for the blades.

Such construction makes it possible in case of a necessary repair or the like to withdraw upwardly the blade bearings and sealing members arranged in a separate detachable sleeve and thereupon to effect the respective repair or replacement. When inserting or withdrawing a sleeve together with a blade journaled therein, the blade has to be moved through the corresponding opening in the wheel body. The obvious thing in such an instance would be to provide such opening with an inner diameter and to dimension the outer diameter of the sleeve so that said inner diameter and outer diameter equals at least the width of the blade. Such a construction, however, would entail an undesired enlargement of the propeller diameter. Therefore, in conformity with a further development of this invention, the outer diameter of the sleeve is designed smaller than the width of the blades. On the other hand, however, the sleeve is provided with two oppositely located extensions, and the opening in the wheel body for such sleeve is provided with corresponding cutouts which supplement the sleeve diameter to the width of the blade. For purposes of installing or removing a blade, it will then merely be necessary to turn the blade to such an extent that the blade profile will register with said extensions. In this instance it is expedient so to arrange the extensions for the sleeve and the cutouts in the wheel body that they are located on the blade circle so that when the control stick occupies its zero or neutral position, all blades will register with the said cutouts and sleeve extensions, thereby avoiding a moving back and forth in order to find the position of the blades in which they can be removed from the wheel body.

Furthermore, it is advantageous to provide a portion of the blade driving lever system with safety means against bending or breaking and preferably to arrange such safety means in the connecting rods. In this way, the parts subject to increased wear and to damage from the outside are separated from the propeller parts, espe-

3

cially driving lever system for the blades, which are not easily accessible and difficult to remove. Such safety means may consist of a ring which is welded at two oppositely located portions to the two ends of the thus interrupted connecting rod. If then, for instance when the ship runs aground, the blade is subjected to a non-permissible load, or if the blade hits a heavy floating body exerting upon the blade such non-permissible load, only the said safety means yields or breaks inasmuch as it is correspondingly weaker than the adjacent parts of the blade wheel construction and can easily be replaced. Thus, damages to the blades themselves as well as to the other parts controlling the blade movements, for instance a bending of the control stick, will be avoided.

Structural arrangement

Referring now to the drawings in detail and Figs. 1 and 2 thereof in particular, the structure shown therein comprises the propeller wheel body 1 which in a manner known per se is driven by means of the hollow shaft 2. The wheel body 1 is supported by the bearing drum 3 of the fixedly arranged propeller casing, said bearing drum 3 extending into the hollow shaft 2. The wheel body 1 carries sleeves 5 detachably arranged therein, while blades 4 by means of their shanks 8 and antifriction bearings 6 and 7 are rotatably journalled in said sleeves 5. To prevent water from entering the blade bearings 6 and 7, the blade shank 8 has the lower end thereof where it enters the sleeve 5 sealed by means of a seal 9. The upper end of the sleeve 5 is provided with a connecting flange 10 extending perpendicular to the longitudinal axis of the sleeve 5. By means of this flange, the sleeve 5 is tightly screwed onto the wheel body 1, whereas the lower end of the sleeve 5 is inserted into the wheel bottom 111 without forming a seal therewith. The water can here enter a chamber confined by the sleeve 5, a partition 12 surrounding said sleeve 5, the wheel body upper portion 11 and the wheel bottom 111. Inasmuch as this chamber does not house any driving elements, no damage will be done when the water enters the said chamber.

In order to make it possible to pull the propeller blade 4, which is wider than the diameter of the sleeve 5, through the wheel body, the wheel bottom 111 as well as the wheel upper part 11 is provided with pairs of recesses or cutouts 13, 14 respectively with the recesses of each pair being arranged opposite each other. The upper pair of recesses 14 is normally covered by a connecting flange 10 of the sleeve 5, whereas the lower pair of recesses 13 is engaged by extensions 15 of the lower sleeve portion. The recesses or cutouts 13 and 14 respectively are located along the blade circle 16 so that the blades 4 will just register with said cutouts 13 and 14 when the control stick 17 occupies its zero position.

The pivot 80 connected by the blade shank 8 to the blade 4 and protruding beyond the sleeve 5 has connected thereto a blade drive lever 18 to which an exchangeable coupling rod 19 is connected. The other end of this connecting rod is connected to the lever arm 20b of a double lever 20 which is rotatably journalled by means of the pivots 20a. The other lever arm 20c of the two-arm lever 20 is arranged to slide in a cross head journalled in the control disc 31. The control disc 31 is adjustable in a manner known per se by means of a control stick 17. The upper end of the control stick 17 is connected to a servomotor S for adjusting the pitch of the blades. The two lever arms 20b and 20c are, as is evident from Fig. 1, located in different planes, the movements of the control center being transferred to the blade drive lever 18 through the intervention of the two-arm lever 20 and the connecting rod 19. Each connecting rod 19 has safety means against bending and breakage built therein. Such safety means may consist of a ring 24 which at two opposite points is welded

4

to the two ends of the two-part connecting rod 19.

In order, when dismantling or assembling the blade wheel according to the invention, to allow lifting and lowering of the blades, or in order to be able to carry out necessary repairs on the blade seals, bearings, etc., the propeller casing is provided with a correspondingly large opening covered by a lid 28. In conformity with the number of propeller blades, openings covering by the lid 29 are arranged in the wheel body.

If, for instance, it is necessary to remove a blade, first the blade body is rotated to such an extent that the blade to be removed will be precisely below the lid 28 covering up the opening of the casing. Inasmuch, as has been mentioned above, the recesses or cutouts 13, 14 are located on the blade circle 16, and since the control stick 17 can any time be returned to its zero position when the propeller is at a standstill, whereby all blades are arranged tangentially with regard to the blade circle 16, also the blade to be removed will register with the two recesses 13 or 14. Thereupon, the oil contained in the wheel body is discharged therefrom at least up to a level somewhat below the upper part 11, so that later on when releasing the sleeve 5, no oil will flow beyond the edge of the upper part 11 and into the water. The two lids 28 and 29 may now be removed by unscrewing the respective screws (not shown) which connect said lids to the adjacent casings whereupon the connecting rod 19 can be removed. Thereupon the connecting screws for flange 10 of sleeve 5 are loosened and are pulled upwardly together with the blades 4 journalled in the sleeve 5.

Whereas with the embodiment of the invention as described in connection with Figs. 1 and 2, the bearing means for the blades are arranged concentrically within the sleeve or removable insert 5, according to the embodiment shown in Figs. 3 and 4, the insert 5 has been replaced by a removable insert 5a, and each blade shaft is eccentrically journalled in said insert 5a so that the axis of the insert or sleeve 5a is located within the blade circle. Furthermore, the diameter of the insert 5a and accordingly the space for said insert 5a in the wheel body is selected so that the axis parallel projection of the blade turned into position for removing the same, i. e. turned into its tangential position, will be located within said space. Such a design has the advantage that the insert can be moved to some extent in the direction toward the wheel center so that also the diameter of the wheel will be correspondingly reduced. The greater the diameter of the space or the greater the diameter of said insert 5a, the closer can the center of said insert be moved toward the center of the wheel. This results not only in a saving of material but also in a reduction of the rotating masses which makes itself correspondingly felt in the propeller drive. Also the sealing at the connecting flange of the sleeve becomes simpler inasmuch as now annular surfaces only are to be sealed with regard to each other.

With specific reference to Figs. 3 and 4, 1a is the propeller wheel body. Each insert 5a has eccentrically arranged therein and connected thereto a sleeve-like body 5b with axially spaced bearings 6a and 6b. The arrangement of Figs. 3 and 4 furthermore comprises a seal 9' inserted between the insert 5a and the reinforced upper portion 11 of the propeller wheel body 1a. The insert 5a is furthermore provided with a flange 10 by means of which the insert 5a rests on the propeller wheel body 11 and may be detachably connected thereto by screws 60.

The sleeve-like body 5b is provided at its lower end with a flange 52 having a lid 53 detachably connected thereto by means of screws 55. As will be clearly evident from Fig. 3, the lid 53 is inserted into the bore 1b of the wheel body 1a. The lid 53 is not connected to the bottom 1c of the wheel body 1a but is inserted into the bore 1b with slide fit so that the insert 5a together with the lid 53 can be lifted out of the wheel body 1a.

5

It will be evident from Fig. 3 that the sleeve-like body 5b is thus guided and properly journalled in the bore 1b at the top by the upper portion of the insert 5a and at the bottom by the lid 53.

Similar to the arrangement of Fig. 1, the arrangement of Fig. 3 also comprises a seal 9a mounted between the flange 52 and an inwardly extending flange 53b of the lid 53 thereby preventing the escape of oil or the entry of water. The seal 9a can easily be removed or exchanged by disconnecting the lid 53 from the sleeve-like body 5b.

The top view shown in Fig. 4 clearly indicates that the center 30 of the sleeve has been moved inwardly by the distance a in order eccentrically to arrange the bearing for the blades in the sleeve. The outer diameter of the wheel body 1 may then be reduced by approximately the same distance a . Inasmuch as the width of the blade 4 is fixed during the construction of the propeller, it will be evident that when displacing the center by a distance a , the diameter for the chambers 32 in the wheel body must be selected at least so that the blade 4 in its position for removal (tangential position) as shown in the drawing can just be pulled through said chambers.

In practice, the distance a and the diameter of the chambers 32 will be adapted to each other in conformity with the respective dimensions and space available.

It is, of course, understood that the present invention is, by no means, limited to the particular constructions shown in the drawings but also comprises any modifications within the scope of the appended claims.

What I claim is:

1. A blade wheel ship propeller with a plurality of removable oscillatable blades having their axes of oscillation at least approximately parallel to each other, which comprises in combination: a hollow rotatable wheel body having a top wall and a bottom wall and having its axis of rotation substantially parallel to the axes of oscillation of said blades, said wheel body having a plurality of pairs of bores with the bores of each pair of bores being coaxially arranged in said top and bottom walls respectively, the number of pairs of bores corresponding in number to the number of said blades, a plurality of sleeve bodies respectively mounted in said pairs of bores and having their axes substantially parallel to the axis of rotation of said wheel body, the upper end of said sleeve bodies being provided with flange means resting on the upper wall of said wheel body, sealing means near the lower end of said sleeve bodies for sealing the latter relative to the bores pertaining thereto, screw means detachably connecting said flange means and thereby said sleeve bodies to said upper wall, the lower ends of said sleeves slidably engaging the bores in said lower wall, additional walls interconnecting said upper and lower walls and forming closed chambers therewith, a plurality of shanks respectively connected to said blades and extending through said sleeves in spaced relationship thereto while having a portion protruding beyond the upper end of said sleeves, a plurality of pairs of bearing means respectively arranged in said sleeve bodies for journalling said shanks, the bearing means of each pair being respectively arranged near said top and bottom walls, and control means operatively and detachably connected to said protruding shank sections for adjusting the positions of said blades.

2. A blade wheel ship propeller with a plurality of removable oscillatable blades having their axes of oscillation at least approximately parallel to each other, which comprises in combination: a rotatable wheel body having its axis of rotation substantially parallel to the axes of oscillation of said blades, said wheel body being provided with a plurality of bores corresponding in number to the number of said blades and having their axes substantially parallel to the axis of rotation of said wheel body, a plurality of sleeves respectively mounted in said bores and detachably connected to said wheel body to allow lifting of said sleeves upwardly out of said bores, a plu-

6

ality of shanks respectively connected to said blades and extending through said sleeves so as to have a section protruding beyond the upper end of said sleeves, said shanks being eccentrically journalled in said sleeves, the axes of oscillation of said blades being located along a circle and the axes of said sleeves being located within said circle, the diameters of said bores for receiving said sleeves being of such magnitude that the blades when occupying their tangential position with regard to said circle are located within the extension of said bores, and control means operatively and detachably connected to said protruding shank sections for adjusting the positions of said blades.

3. A blade wheel ship propeller with a plurality of removable oscillatable blades having their axes of oscillation at least approximately parallel to each other, which comprises in combination: a hollow rotatable wheel body having a top wall and a bottom wall and having its axis of rotation substantially parallel to the axes of oscillation of said blades, said wheel body being provided with a plurality of pairs of bores with the bores of each pair of bores provided in the top and bottom walls, the number of pairs of bores corresponding in number to the number of said blades, a plurality of sleeves respectively mounted in said pairs of bores and having their axes substantially parallel to the axis of rotation of said wheel body, the upper end of said sleeves being provided with flange means resting on the upper wall of said wheel body, a plurality of shanks respectively connected to said blades and extending through said sleeves so as to have a section protruding beyond the upper end of said sleeves, control stick means having a portion coaxially arranged with regard to said wheel body, a plurality of two-arm control levers respectively provided with stud means pivotally journalled in said wheel body and having an upper lever arm and a lower lever arm, a plurality of exchangeably arranged connecting rod means respectively connecting said upper arms with said protruding shank sections, each of said rod means being composed of a plurality of sections of substantially the same resistance against breakage and including connecting means interconnecting said last mentioned sections and having less resistance against breakage than said last mentioned sections, and means operatively connecting said lower arms with said portion of said control stick means.

4. A blade wheel ship propeller with a plurality of removable, oscillating blades having their axes of oscillation at least approximately parallel to each other, which comprises in combination: a hollow rotatable wheel body having a top wall and a bottom wall and having its axis of rotation substantially parallel to the axes of oscillation of said blades; said wheel body being provided with a plurality of bores corresponding in number to the number of said blades; a plurality of sleeve bodies respectively mounted in said bores and having their axes substantially parallel to the axis of rotation of said wheel body; each of said sleeve bodies comprising a cylindrical member slidably engaging the upper portion of the respective adjacent bore and provided with a peripheral flange resting on said top wall, a sleeve eccentrically arranged in said cylindrical member and connected thereto, and a disc-like member connected to said sleeve and slidably engaging the lower portion of the respective adjacent bore and being provided with a bore coaxial with the respective adjacent sleeve; first sealing means interposed between each of said cylindrical members and the wall of the adjacent bore, second sealing means interposed between each disc-like member and the adjacent wall of the respective adjacent bore; first connecting means respectively detachably connecting the cylindrical members of said sleeve bodies to said top wall, second connecting means respectively detachably connecting said disc-like members to the respective adjacent sleeves; a plurality of shanks respectively connected to said blades and extending through said sleeves in spaced relationship thereto while

7

having a portion protruding beyond the upper end of said sleeves; a plurality of pairs of bearing means respectively arranged in said sleeves for journalling said shanks; the bearing means of each pair being respectively arranged near the top and bottom ends of said sleeves; and control means operatively and detachably connected to said protruding shank sections for adjusting the positions of said blades.

8

References Cited in the file of this patent

UNITED STATES PATENTS

2,015,514	Ehrhart	Sept. 24, 1935
2,037,069	Ehrhart	Apr. 14, 1936
2,230,708	Wahl	Feb. 4, 1941
2,678,019	Couch	May 11, 1954

5